

FDL3TRGW301NW10

Specifications

Commercial Dryer

Model	FDL3TRGW301NW10
General details	
Control	3 Cycle Mechanical
Control location	Rear
Actuation	None
Drum	
Capacity kg	10.5
Volume l	198
Power	
Motor power kW	0,25
Voltage	220 - 240/50/1
Cabinet	
Cylinder Finish	Galvanized
Color	White
Door type	Window
Connections	
Electrical requirements	220 - 240/50/1
Transport data	
Net weight kg	--
Shipping weight kg	--
Dimensions HxWxD mm	1093 x 683 x 722
Packed dimensions HxWxD mm	1156 x 775 x 864
Packed volume l	773

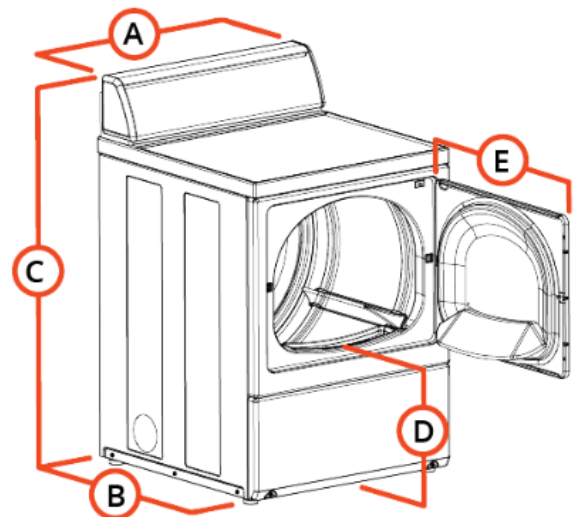

Dimensions

	mm
A	683
B	722
C	1093
D	392
E	597